

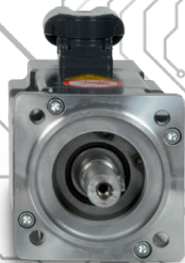

DRIVE BASED SAFETY



# COMBIVERT S6

COMPACT SERVO DRIVES

EN



## CONTENT

## PAGE

System overview	3
Benefits at a glance	4
COMBIVERT S6 versions	6
Functional Safety	8
Electrical properties	10
Mechanical data, operating types, standards	11
Servo Motors DL3	12
Planetary gear	13
Servo Gear Motors	14
Servo Motors TA	15
DL3 cables	16
TA cables	17
Accessories	18
My Drive	19
Combivis 6	20
KEB Service	22
KEB worldwide	23

[www.keb.de](http://www.keb.de)

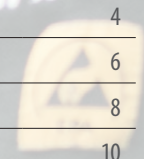

# SYSTEM OVERVIEW

## Automation with Drive

stands as a synonym for optimally selected combinations of control and automation solution. With the drive level at the end it is the key to successful machine concepts.

Let the following pages inspire you with regards to the diversity and performance of the COMBIVERT S6 servo system, and help you to find a solution that reliably meets your requirements.

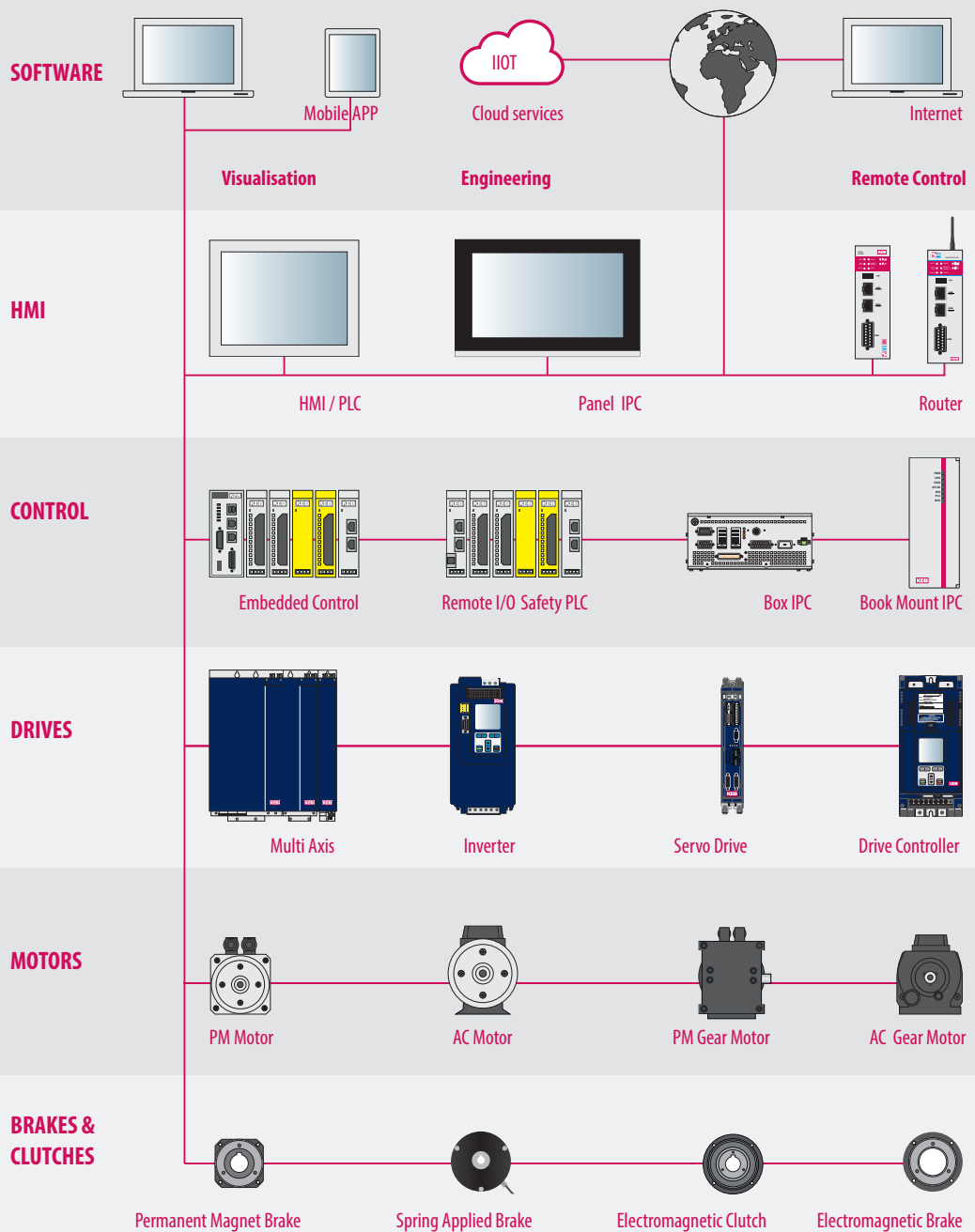

## COMBIVERT S6 - BENEFITS AT A GLANCE

### OPTIMALLY SELECTED COMPONENTS

The COMBIVERT S6 servo system adds a compact, flexible and powerful drive module to the KEB product portfolio for highly dynamic servo applications. The optimally selected KEB components are the key to this successful drive concept.

- At the heart, the innovative S6 servo drive is offered in an attractive book-style format and offers real-time performance. The S6 drives can be matched with the robust DL3 servo motors which are available in five sizes. Additionally, the DL3 servo motors may be paired with planetary gearheads with low rotational backlash.
- The TA series combines in direct connection the servo motor and industrial gears in the designs helical, helical bevel, helical worm and flat. You can now design the complete servo drive system that is best suited to your application.

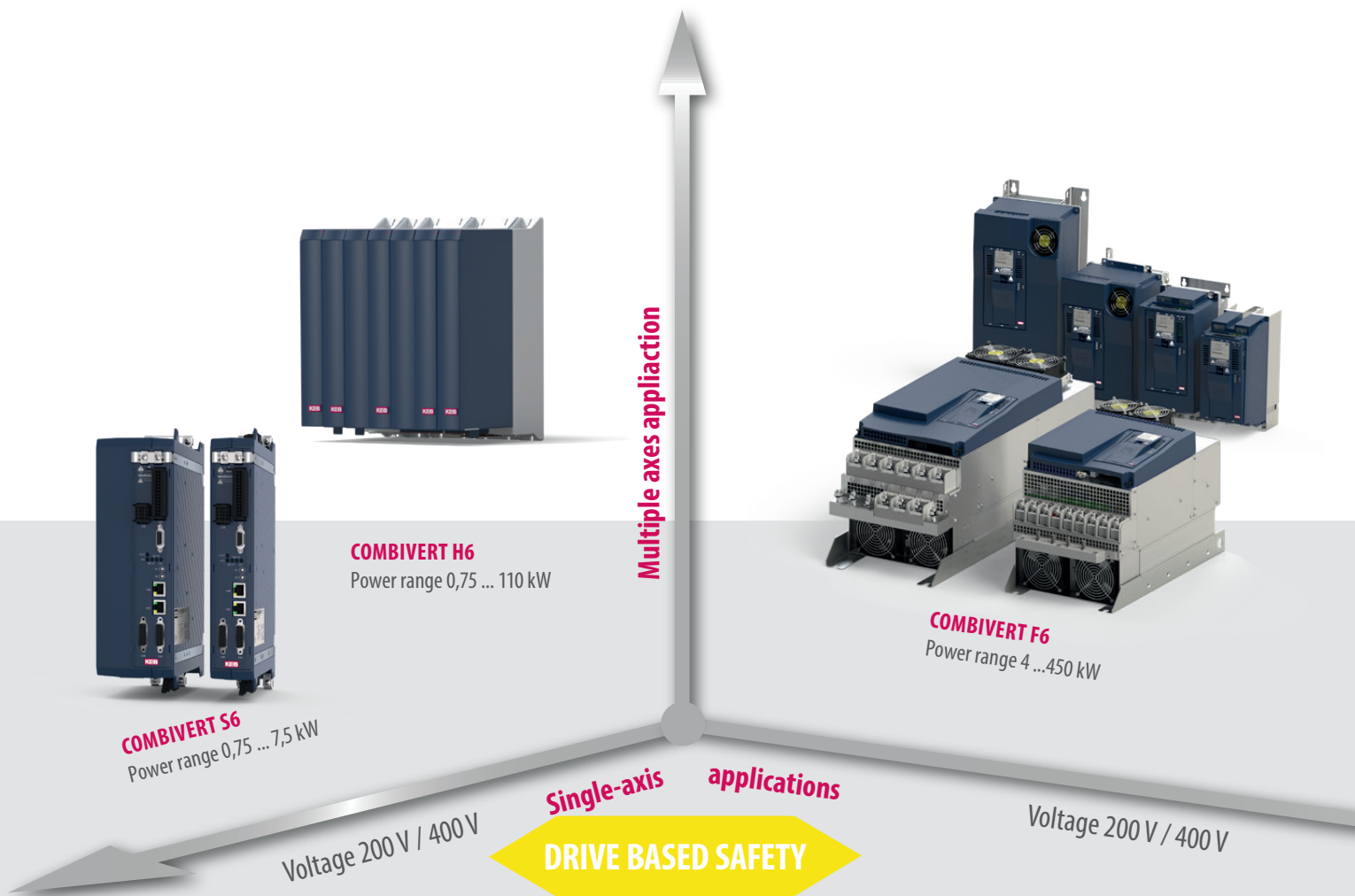

The package is made complete with pre-fabricated motor and encoder cables, which create the ideal conditions for easy installation, quick start-up and problem-free operation. For the upper power range the new COMBIVERT F6 drive controller completes the drive line with 1:1 features up to 450 kW.

### POSSIBLE SELECTION: S6 SERVO DRIVE AVAILABLE WITH OR WITHOUT INTEGRATED EMC FILTER

- 2.6 ... 16.5 A in two enclosures with six electrical sizes
- Book format for space-saving control cabinet configuration
- Direct connection to the mains for 230 V and 400-480 V grids, DC-input is also available, 260 ... 375 / 750 V
- Low leakage current mains filter (<5 mA) integrated, optional without filter
- High overload for excellent dynamics (250% / 3 s, 200% / 60 s)

## DRIVE BASED SAFETY

- Integrated Safety functionality
- Basic function STO in Compact version
- Additional modular High level Safety in Application version
- Encoderless safety in version PRO

## REAL-TIME COMMUNICATION

- Real-time Ethernet-based interfaces
  - CAN
- or simply serial:
- RS232 / 485 for diagnostics or display

## ALL IN ONE - UNIVERSAL MOTOR OPERATIONS

- Control for asynchronous, synchronous, IPM or synchronous reluctance motors
- Motor operation with encoder feedback or encoderless ASCL / SCL for precise speed control
- Motor temperature monitoring with PTC, KTY or PT1000 sensors
- Two-channel multi-encoder interface
- Integrated brake transistor
- Integrated brake control and brake supply

## ANALOG & DIGITAL I / O

supports actual machine concepts with:

- 8 digital and 2 analog inputs
- 2 digital and 1 relay output
- 1 analog output 0 ... 10 V



## HIGHLIGHTS

- Uncompromising integration, highest performance
- Modern realtime communication standards
- Integrated functional safety
- Particular compact size
- Modular design, flexible cooling systems

# COMBIVERT S6

## MAINS CONNECTIONS

with pluggable terminals

## FUNCTIONAL SAFETY

## INTERFACE

CAN interface

## REALTIME ETHERNET

## DC SUPPLY TERMINALS

and braking resistor

## MOTOR TERMINALS

with pluggable terminals

## I/O

8 digital inputs  
2 digital outputs  
1 relay  
2 analog inputs  
1 analog output  
24V DC supply

## DIAGNOSTIC INTERFACE

## STATUS LEDs

## MULTI ENCODER INTERFACES

Resolver, EnDAT, Hiperface, BISS, SSI,  
Incremental HTL/TTL,  
Incremental output

## KTY / PTC / PT1000 EVALUATION

## BRAKE CONTROL 24 V / 2 A

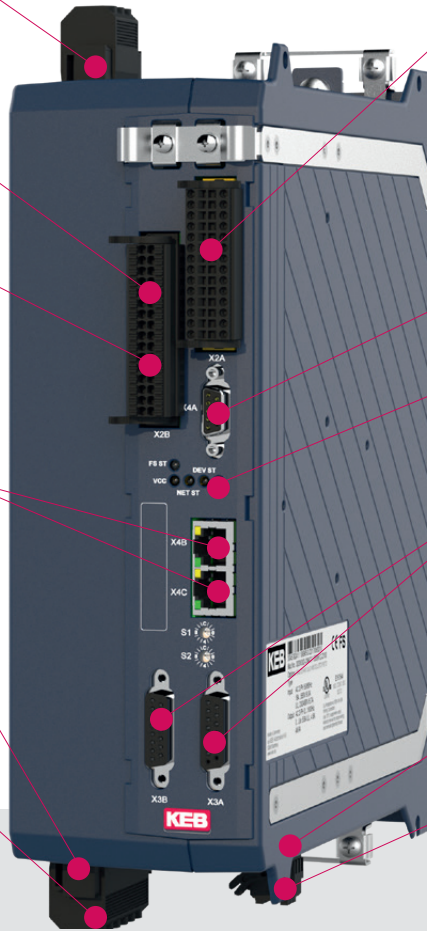

EtherCAT®

Safety over  
EtherCAT®



CANopen®



## HIGHLIGHTS

- Compact and flexible servo system
- Highest performance in torque, speed and position control
- Uncompromising integration
- User-friendly
- Scalable safety functions...

**COMPACT**  
**HIGHLY INTEGRATED**  
**AND ECONOMICAL**

STO

**REALTIME ETHERNET**

**ETHERCAT OR VARAN**

Communication interface

**CAN**

**DIAGNOSTIC RS232 / 485**

**APPLICATION**  
**MODULAR AND FLEXIBLE**

STO, SBC and speed / position related safety functions

**REALTIME ETHERNET**

**ETHERCAT (FSoE)**  
**PROFINET**  
**POWERLINK**  
**ETHERNET / IP**

Communication interface

**CAN**

**DIAGNOSTIC RS232 / 485**

**PRO**  
**ENCODERLESS SAFETY**

STO, SBC and speed related safety functions without encoder feedback

**REALTIME ETHERNET**

**ETHERCAT (FSoE)**

Communication interface

**CAN**

**DIAGNOSTIC RS232 / 485**



**HIGHLIGHTS**

- Brake handling
- Power-off
- DC-brake
- PID controller
- Round table function
- Recipe management
- Multi motor handling
- Anti cogging
- Management liquide cooling
- Etc.

# SAFETY FUNCTIONS IN THE DRIVE

## BASIS FOR SAFETY

### COMPACT

In the Compact version, the COMBIVERT F6 and S6 drive controllers are equipped with Safe-Torque-Off (STO).

## SAFETY FUNCTIONS WITH SPEED AND POSITION MONITORING

### APPLICATION

The device variant Application is available in two versions. In addition to STO, Module 1 adds safe brake control (SBC) which provides a safe 24 V supply for the brakes.

Module 3 offers safe motion functionality according to IEC 61800-5-2 through speed and position detection using encoders.

The error reaction time is shortened and costs are reduced by reducing the number of separate protective devices. Module 3 also offers the option of controlling all available safety functions and limit values via Safety over EtherCAT (FSoE).

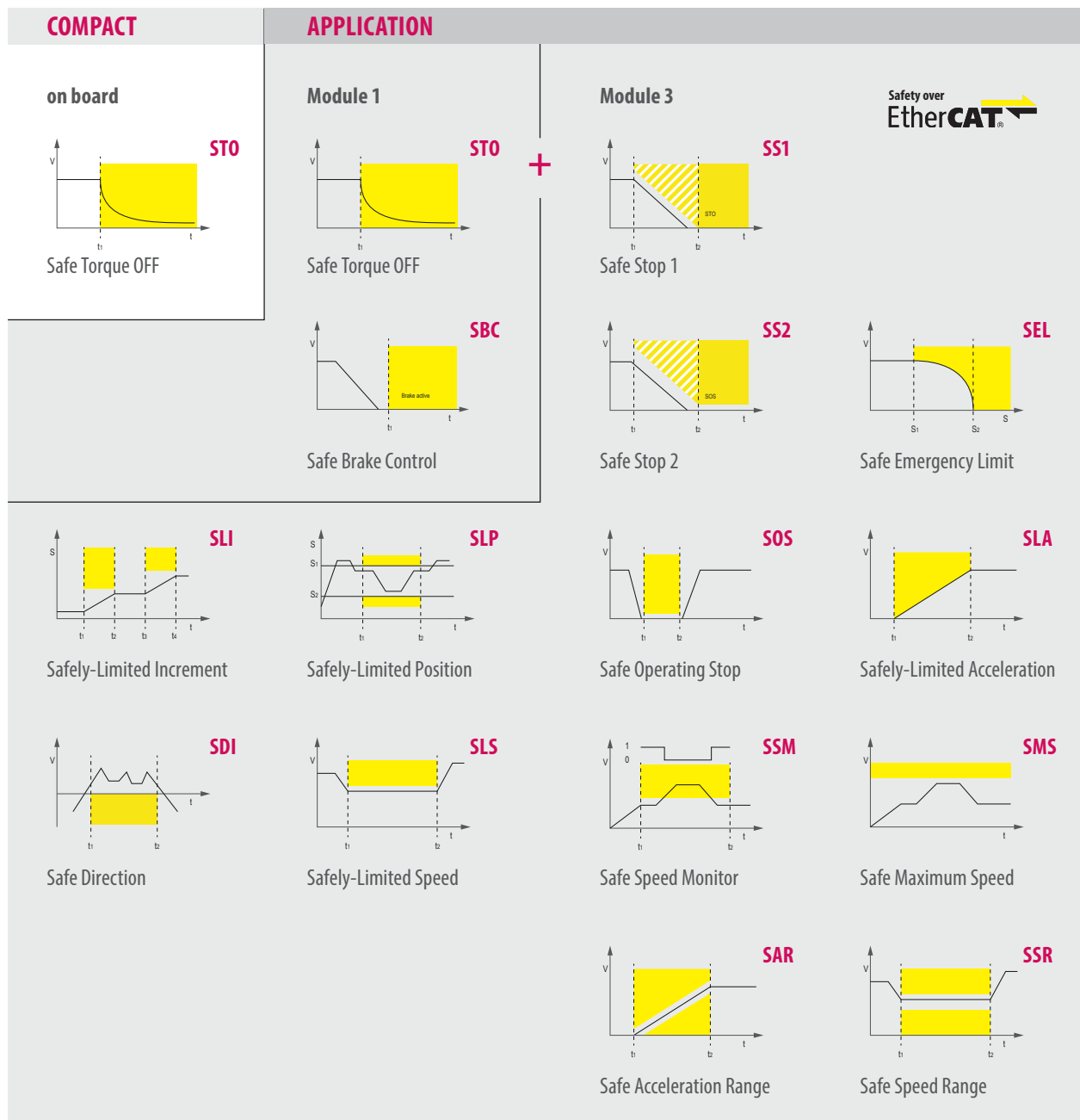



## ENCODERLESS SAFETY FUNCTIONS

### PRO

The PRO device variant of the COMBIVERT F6 and S6 drive controllers offers advanced safety functions without having to use a safety encoder. The device determines the safe velocity parameters from the pulse width modulation (PWM) of the motor supply.

In addition to STO, Module 5 is equipped with a safe brake control (SBC), which provides a safe 24 V supply for braking operation as well as a monitoring of the switching status of the brake via microswitch evaluation.

Module 5 also offers the option of controlling all available safety functions via Safety over EtherCAT (FSoE).

**PRO**

**Module 5**

**STO**

Safe Torque OFF

**SLS**

Safely-Limited Speed

**SS1**

Safe Stop 1

**SLA**

Safely-Limited Acceleration

**SMS**

Safe Maximum Speed

**SBC**

Safe Brake Control

**SSM**

Safe Speed Monitor

**SDLC**

Safe Door-Lock Control

Safety over  
**EtherCAT**



### WHY USE DRIVE-BASED SAFETY (SAFE MOTION)?

- Less wiring - remove contactors and other traditional safety components
- Fast reaction - direct handling inside the drive
- Easy to operate - up to eight different safety setups per function
- Cost savings compared to traditional safety solution

# COMBIVERT S6

## ELECTRICAL PROPERTIES

HOUSING			2				4			
Device size			07	09	07	09	10	12	13	14
Mains phases			1		3					
<b>Output rated current</b>	$I_N$	[A]	<b>4</b>	<b>7</b>	<b>2.6</b>	<b>4.1</b>	<b>5.8</b>	<b>9.5</b>	<b>12.0</b>	<b>16.5</b>
Short maximum current (3 s / 60 s) <sup>1)</sup>	$J_{SMC}$	[%]	200 / 150		250 / 200					180 / 150
Output rated power *	$S_A$	[kVA]	1.8	2.8	1.8	2.8	4	6.6	8.3	11.4
Typical rated motor power	$P_{mot}$	[kW]	0.75	1.5	0.75	1.5	2.2	4.0	5.5	7.5
			230 V			400 V				
Max. current 0 Hz / cutoff frequency at $f_s = 4$ kHz <sup>1)</sup>	$I_0$	[%]	175 / 240	157 / 240	215 / 300	193 / 300	155 / 284	273 / 300	283 / 300	133 / 216
Max. current 0 Hz / cutoff frequency at $f_s = 8$ kHz <sup>1)</sup>	$I_0$	[%]	150 / 240	114 / 228	162 / 292	132 / 234	103 / 206	189 / 294	183 / 293	109 / 212
Max. current 0 Hz / cutoff frequency at $f_s = 16$ kHz <sup>1)</sup>	$I_0$	[%]	100 / 200	85 / 200	92 / 200	73 / 146	50 / 120	105 / 189	116 / 175	60 / 127
Cutoff frequency point	$f_d$	[Hz]	6							
Input rated current	$I_{IN}$	[A]	8	14	3.6	6	8	13	17	21
Max. permissible mains fuses	Typ gG	[A]	15	20	6	10	10	15	20	25
Rated switching frequency	$f_{SN}$	[kHz]	8							4
Max. switching frequency	$f_{Smax}$	[kHz]	16							
Rated losses	$P_D$	[W]	60	95	50	57	80	155	185	250
Standby losses	$P_{Dnop}$	[W]	8							
Min. brake resistance	$R_{Bmin}$	[Ω]	56	33	160	110	82	33	25	25
Max. braking current	$I_{Bmax}$	[A]	7.5	12.7	5.5	8	11	28	34	34
Input rated voltage (AC)	$U_N$	[V]	1-phase 230			3-phase 400 (UL: 480)				
Input voltage range (AC) <sup>2)</sup>	$U_{in}$	[V]	184 ... 265			184 ... 550 ±0				
Input voltage range (DC)	$U_{indc}$	[V]	260 ... 375			260 ... 750 ±0				
Mains frequency	$f_N$	[Hz]	50 / 60			50 / 60 ±2				
Output voltage	$U_A$	[V]	3 x 0 ... $U_{IN}$							
Output frequency	$f_A$	[Hz]	0 ... 599 optional 0 ... 2000							

\* At rated voltage 400 V AC

<sup>1)</sup> The figures relate to the output rated current  $I_N$  on a percentage basis

<sup>2)</sup> In the case of rated voltage  $\geq 460$  V, multiply rated current with a factor of 0.86

## OPERATING TYPES, STANDARDS

### OPERATING MODES

Motor control mode	<b>PMSM:</b> field-oriented with encoder, S.C.L. encoderless <b>IPMSM:</b> field-oriented with encoder, S.C.L. encoderless <b>SyncRM:</b> field-oriented with encoder, S.C.L. encoderless <b>ASM:</b> V / F, field-oriented with encoder, A.S.C.L. encoderless
Application profile	CiA 402
Control mode	Velocity Mode Cyclic Synchronous Velocity Mode Cyclic Synchronous Torque Mode Cyclic Synchronous Position Velocity Mode Profile Position Mode Homing Mode Jog Mode

### GENERAL

Product standard	EN 61800-2, -5-1
EMC transient emissions	
Grid-bound disturbance	EN 61800-3, C2 - 1-ph: 30 m - 3-ph: 50 m motor cable length (shielded), low-capacitance
Emitted disturbances	EN 61000-6 -1...4, C2
Protection class	IP 20 / VBG 4
Environment	EN 60721-3-3 Operating temperature -10 ... 45 °C Storage temperature -25 ... 55 °C Humidity 3K3 - 5 ... 85% (no condensation)
Site altitude	max. 2,000 m above sea level, from 1,000 m: power reduction of 1 % per 100 m

HOUSING	2	4
H1	265	265
H2	275	275
H3	310	310
D	220	220
W	50	90

All dimensions in mm

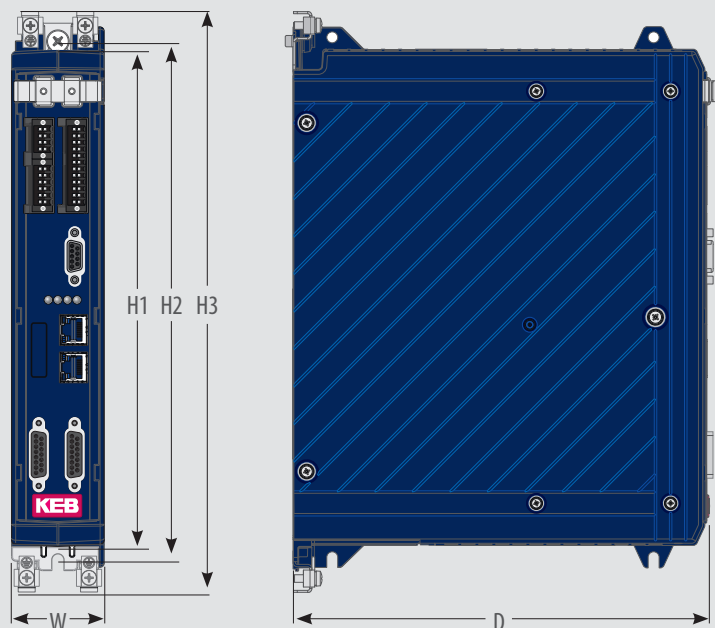

# SERVO MOTORS

## SERVOMOTORS DYNAMIC LINE 3

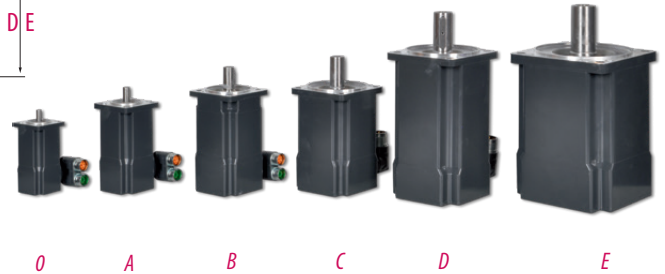
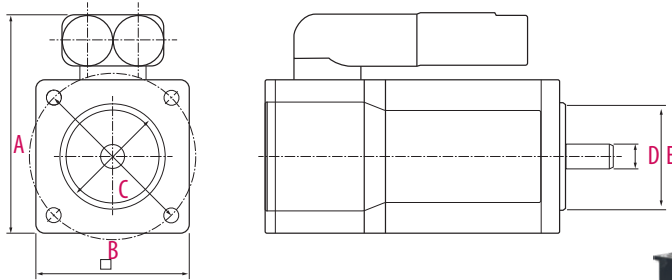

O_SMH_	<b>0.2 ... 0.5</b>												
A_SMH_		<b>0.5 ... 1.2</b>											
B_SMH_			<b>1.38 ... 3.22</b>										
C_SMH_				<b>2.45 ... 5.65</b>									
D_SMH_					<b>4.9 ... 11.4</b>								
E_SMH_						<b>12.8 ... 29.0</b>							Stall torque in Nm

MOTOR	$T_0$ [Nm]	$T_N$ [Nm]	$U_N$ [V]	$I_{d0}/I_N$ [A]	$N_N$ [min <sup>-1</sup> ]	A [mm]	B [mm]	C [mm]	D [mm]	E [mm]	OPTION BRAKE $T_n$ [Nm]	INERTIA $J_M / J_{MwBr}$ [kgcm <sup>2</sup> ]
O1	0.2	0.18		0.76 / 0.73								0.0294 / 0.0521
O2SMHF_	0.38	0.33	230	1.3 / 1.2	8000	65.4	40	46	8	30	0.6	0.0482 / 0.0709
O3	0.52	0.45		1.65 / 1.3								0.0670 / 0.0897
A1	0.5	0.5		0.85								0.134 / 0.205
A2SMHF_	0.8	0.7		1.50 / 1.30	8000	82.4	58	63	9	40	0.8	0.253 / 0.324
A3	1.2	1.0		2.20 / 1.85								0.373 / 0.444
B1	1.4	1.3		1.95 / 1.90								0.462 / 0.541
B2SMHF_	2.4	2.2		2.95 / 2.75	6000	96.4	72	75	14	60	2	0.842 / 0.921
B3	3.2	2.7		4.10 / 3.60							3.5	1.22 / 1.46
C1	2.5	2.3		3.00 / 2.90	6000							1.08 / 1.74
C2SMHF_	4.1	3.7	400	4.10 / 3.80	5000	128.5	87	100	19	80	9	1.98 / 2.63
C3	5.7	4.9		5.40 / 4.75	5000							2.87 / 3.52
D1	4.9	4.4		4.75 / 4.20	5000						9	2.23 / 2.89
D2SMHF_	8.2	6.9		6.30 / 5.20	4000	145.5	104	115	24	95	9	4.06 / 4.72
D3	11.4	8.4		8.80 / 6.30	4000						13	5.88 / 7
E1	12.8	11.0		7.80 / 6.80							20	11.1 / 1.34
E2SMHF_	21.1	15.2		12.4 / 9.40	3000	183.5	142	165	32	130	20	20 / 22.3
E3	29.0	13.2		17.2 / 8.10							30	29 / 34.9



### HIGHLIGHTS

- 0.2 ... 29 Nm in six frame sizes
- Low inertia – high impulse torque
- Resolver or absolute rotary encoder, HIPERFACE single or multi-turn
- High degree of total efficiency
- Lifetime lubricated
- Universal installation positions
- Robust mechanics (optional: COMBIPERM holding brake, keyway with key, IP65 shaft sealing)

**PLANETARY GEAR SG PAIRED WITH DYNAMIC LINE 3**

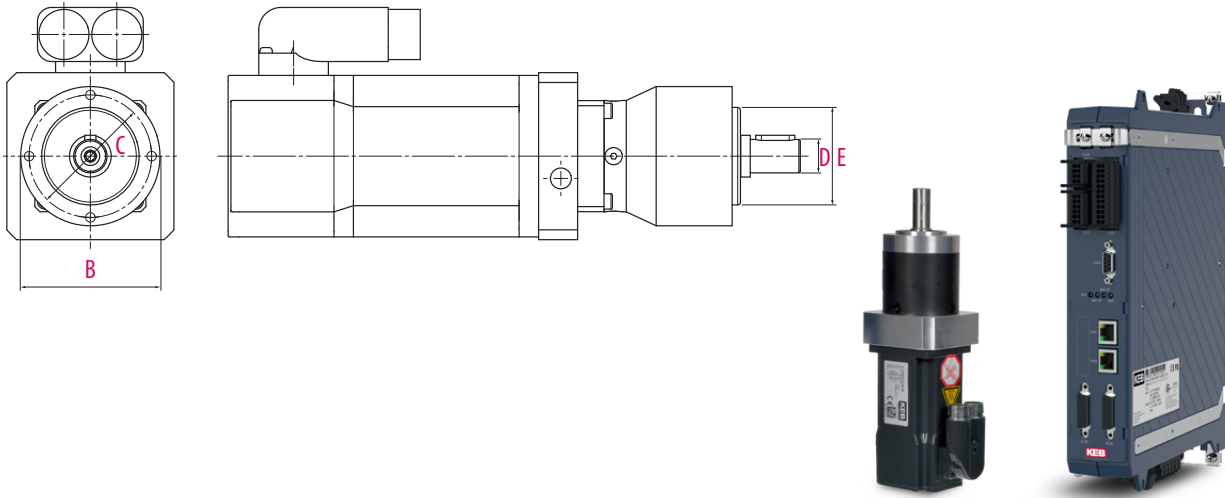

GEAR SIZE	T <sub>2N</sub> [Nm]	T <sub>2MAX</sub> [Nm]	N <sub>MAX</sub> [rpm]	I	BACKLASH arc <sub>min</sub>	B Ø [mm]	C Ø [mm]	D Ø [mm]	E Ø [mm]	DL3-MOTOR recommended
1	5 ... 11	8 ... 17.5	5000	5 ... 40	15	50	44	12	35	A
2	15 ... 28	24 ... 45	4500		10	70	62	16	52	A B C
3	38 ... 85	61 ... 136	4000		7	90	80	22	68	A B C D
5	95 ... 115	152 ... 136	3000		7	120	108	32	90	B C D E
7	210 ... 460	336 ... 736	2800		8	155	140	40	120	C D E

**SIMPLE SELECTION AND ORDERING BY SYSTEM CONFIGURATION IN COMBIVIS 6**

- Output torque and speed
- Gear ratio
- Motor size



**HIGHLIGHTS**

- Low backlash
- High output torque
- High efficiency (97 %)
- Gear ratios i = 5 to 40
- Low audible noise
- Lifetime lubricated

# SERVO GEAR MOTORS

## INTEGRATED SERVO DESIGN

Based on the industrial standard with AC motors the portfolio of COMBIGEAR series offers a full basket of servo gear solutions. The dynamic and efficient TA servo motors are direct connected in the first gear stage – best choice for minimum lengths, nearly zero wear and small inertia of the gear motor system.

Flexible designs for flange-, foot-, or combined flange / foot- mounting and a wide range of options secure individual needs in the machine. Ultra-fine speed ratio range, adjustable down to speed 0, enables optimum adaptation of torque and speed on output. Life-time lubrication, high overload and low torsional backlash ensure a long service life.

TYPE	SIZE	DESIGN	$T_N$ [Nm]	I	TA1	TA2	TA3	TA4	TA5
G	0 ... 7	Helical gear	60 ... 4880	3.37 ... 250.97	■	■	■	■	■
F	2 ... 7	Shaft mounted helical gear	245 ... 4880	3.20 ... 274.23		■	■	■	■
K	0 ... 7	Helical bevel gear	58 ... 4880	3.38 ... 183.21	■	■	■	■	■
S	0 ... 4	Helical worm gear	55 ... 1160	5.09 ... 247.58	■	■	■	■	■

HELICAL GEAR

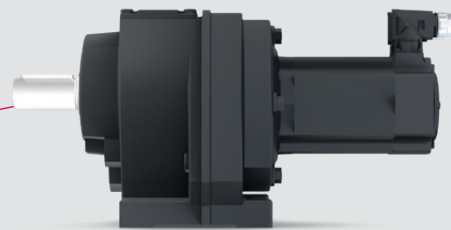
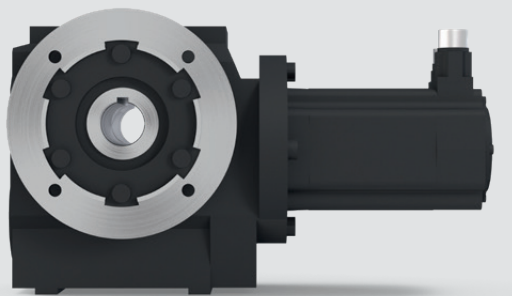

HELICAL WORM GEAR

SHAFT MOUNTED HELICAL GEAR

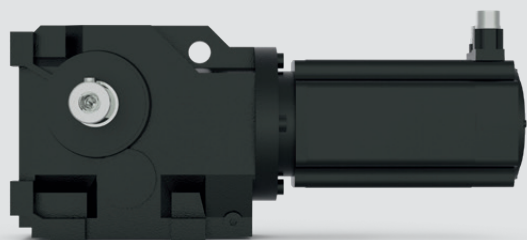

HELICAL BEVEL GEAR

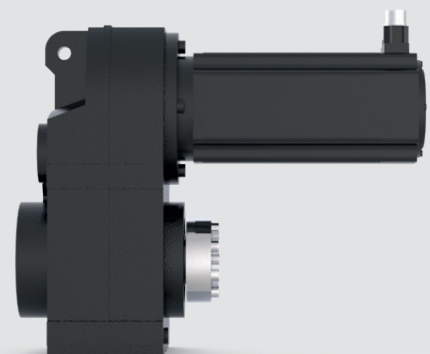

TA SERIES

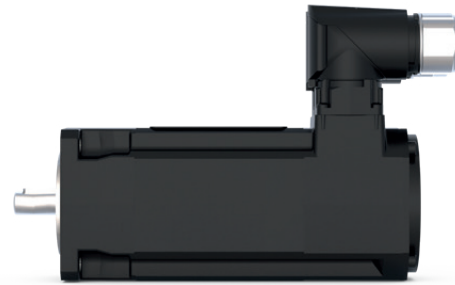
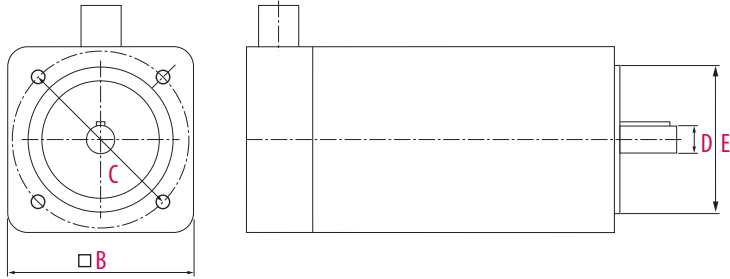

TA 1	0.5 ... 0.9
TA 2	1.3 ... 3.3
TA 3	2.9 ... 6.8
TA 4	6.9 ... 11,7
TA 5	11.5 ... 20.0

Stall torque in Nm

MOTOR	T <sub>0</sub> [Nm]	U <sub>N</sub> [V]	I <sub>do</sub> [A]	N <sub>N</sub> [min <sup>-1</sup> ]	B [mm]	C [mm]	D [mm]	E [mm]	OPTION BRAKE T <sub>n</sub> [Nm]	INERTIA J <sub>M</sub> / J <sub>MwBr</sub> [kgcm <sup>2</sup> ]
TA1S	0.5	400	0.95 / 0.72	6000 / 4500	58	63	9	40	2	0.14 / 0.2
TA1M	0.9		1.11 / 0.84							0.2 / 0.27
TA2S	1.4		1.6 / 1.1	6000 / 4500	75	75	11	60	2	0.39 / 0.46
TA2M	2.4		2.75 / 2							0.66 / 0.73
TA2L	3.3		3.9 / 2.8							0.93 / 0.99
TA3S	2.9		3.4 / 2.5 / 1.82	6000 / 4500 / 3000	90	100	14	80	4,5	1.13 / 1.32
TA3M	4.9		6.2 / 4.1 / 2.55							1.95 / 2.13
TA3L	6.8		7.3 / 5.6 / 3.8							2.76 / 2.94
TA41	6.9		6.5 / 4.45 / 3.15	4500 / 3000 / 2000	116	115	19	95	9	5.65 / 5.83
TA42	9.2		8.5 / 5.9 / 4							8.15 / 8.69
TA43	11.7		11.2 / 7.3 / 5							10.65 / 11.19
TA51	11.5		11 / 7.4 / 5	4500 / 3000 / 2000	145	165	24	130	18	14.97 / 16.63
TA52	16.1	15.8 / 10.3 / 6.9	21.53 / 23.19							
TA53	20	19.2 / 12.8 / 8.7	28.15 / 29.81							

further technical data and motor sizes see KEB-Drive product configuration



HIGHLIGHTS

- 0.5 ... 20 Nm in five frame sizes
- Low inertia – high impulse torque
- Easy plug connection, straight or angled (360° rotatable)
- Compact size - directly integrated in the gear modules
- High total efficiency, lifetime lubricated, universal installation positions and robust mechanics
- Resolver or absolute rotary encoder, BiSS single and multi-turn
- Optionally with COMBIPERM holding brake

# SERVO MOTORS

## DL3 CABLES FEEDBACK AND POWER CABLES

Pre-fabricated motor and encoder cables ensure the easy commissioning and simplify the final installation. General performance is the high-quality and flexible design for all cables, made for drag chains. Quick and tool-less installation with Speedtec plug connectors guarantees an optimal connection and EMC shielding.



### RESOLVER FEEDBACK CABLES

- motor side connector - series 615
- drive side connector D-sub 26 pin

### 00S6L50-00

cable length	1...30 m	in 1 m steps
	35...50 m	in 5 m steps

### HIPERFACE FEEDBACK CABLES

for single and multi turn encoders

- motor side connector - series 615
- drive side connector D-sub 26 pin

### 00S6L55-00

cable length	1...30 m	in 1 m steps
	35...50 m	in 5 m steps

### MOTOR CONNECTION CABLES

- motor side connector - series 615 motor sizes 01 ... 03 and A...B
- drive side open end with 0.3 m open shielding

### 00H6L10-00

cable length	1...30 m	in 1 m steps
	35...50 m	in 5 m steps

- motor side connector - M23 speedtec motor size C - E

### 00S4519-00

cable length	1...30 m	in 1 m steps
	35...50 m	in 5 m steps



## HIGHLIGHTS

- Pre-fabricated motor and encoder cables for easy installation
- High-quality and flexible design for cable drag chains
- Quick and tool-less installation with Speedtec plug connectors
- Optimally integrated shield connection
- Available in lengths up to 50 metres



## TA CABLES FEEDBACK AND POWER CABLES

Prepared for the direct connection:

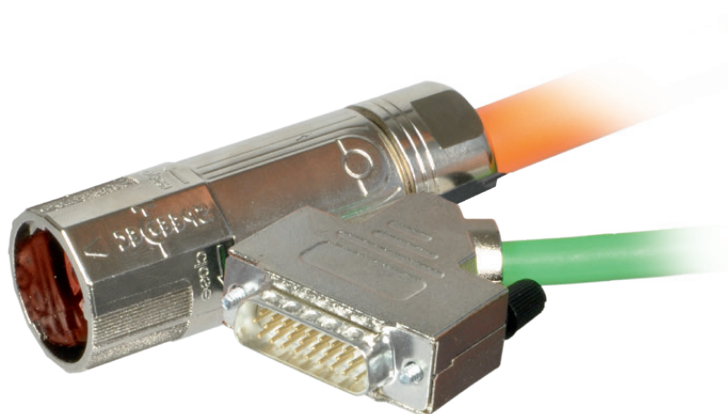

### RESOLVER FEEDBACK CABLES

- motor side connector - 12 pin M23 - Speedtec
- drive side connector D-sub 26 pin

#### 00S6L50-10\_\_

cable length	1...30 m	in 1 m steps
	35 .. 50 m	in 5 m steps

### BISS FEEDBACK CABLES

for multi turn encoders

- motor side connector - 17 pin M23 - Speedtec
- drive side connector D-sub 26 pin

#### 00S6L51-20\_\_

cable length	1...30 m	in 1 m steps
	35 .. 50 m	in 5 m steps

### HIPERFACE FEEDBACK CABLES

for single and multi turn encoders

- motor side connector - series 615
- drive side connector D-sub 26 pin

#### 00S6L55-10\_\_

cable length	1...30 m	in 1 m steps
	35...50 m	in 5 m steps

### MOTOR CONNECTION CABLES

- motor side connector - M23 - speedtec for motor size TA2...TA5
- drive side open end with 0.3 m open shielding

#### 00S4519-00\_\_

cable length	1...30 m	in 1 m steps
	35...50 m	in 5 m steps

## ACCESSORIES

### MAINS CHOKE

Mains chokes reduce the input peak current draw and the mains distortion. By smoothing the input current draw, the lifetime of the drive is enhanced, in particular at constantly high utilization.

#### Mains choke 3-phases 400 V AC ( $U_{max} = 550 \text{ V}$ ), 50 / 60 Hz

Part-No.	$I_N$ [A]	$P_V$ [W]	$f_{Main}$ [Hz]	W [mm]	H [mm]	D [mm]	Weight m [kg]
07Z1B04-1000	2.7	19	45-65	100	55	121	0.9
09Z1B04-1000	4.3	23	45-65	100	55	121	1.1
10Z1B04-1000	6.1	24	45-65	100	64	121	1.5
12Z1B04-1000	10	37	45-65	148	68	145	2.1
13Z1B04-1000	12.6	48	45-65	148	78	145	2.6

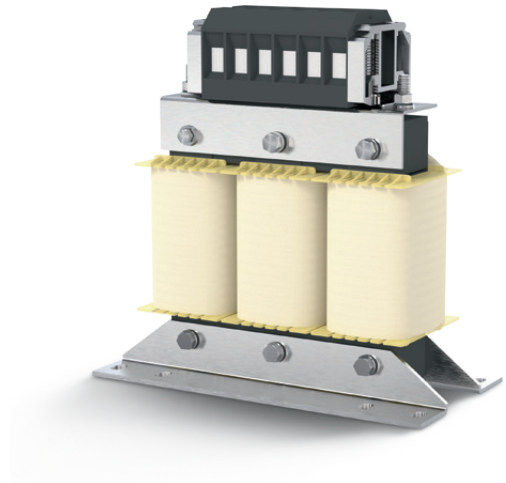

### BRAKING RESISTOR

Braking resistors can be connected to the series terminals of the brake transistor, and ensure that energy peaks are absorbed and discharged. The compact design require only small space and they are intrinsically safe; without additional temperature sensors.

To protect against overheating and fire hazards, the brake resistors feature thermal monitoring which can be integrated into the external circuit.

#### BRAKING RESISTORS – “INTRINSICALLY SAFE”

Part Number	$P_D$ [W]	R [Ω]	W [mm]	H [mm]	D [mm]	Wire [m]	Protection class
10G6A90-4300	200	160	220	90	31	0.2	IP40
13G6B90-4300	250	110	285	90	31	0.2	IP40
15G6C90-4300	300	56	295	120	31	0.2	IP40

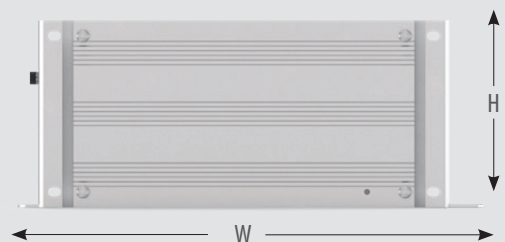

In addition to the defined base versions COMPACT and APPLICATION the COMBIVERT S6 unit offers specific application adjustments and customization.

**HIGH SPEED SPINDLE DRIVES**

- Maximum output frequency 2,000 Hz

HIGHSPEED >>>>



**SPECIFIC FIRMWARE**

- Fixed software versions according tested application specification

**APPLICATION READY TO START**

- Customer specific parameter lists stored on the drives internal file server ex works

**CUSTOMER LABELLING**

- Specific name plate for series OEM with first line service concept

YOUR LOGO

**EXTENDED WARRANTY**

- 24 months warranty
- 36 months warranty

**CONNECTOR SHIELDING SET**

- Drive controller with connector and shielding set

Meta\_LSM\_EtherCAT 2017\_11\_14\_Temp\_Project\_Backup

Quelle-Config-Id: 9282

Parameter	#	Grdf	Grdf	Grdf	Adress...	Sw...	Setz	R/W	Drf...	Name	Offline-Wert	Online-Wert	Bemerkung
	1	0	0	0	0	0	0	0	0	parameter	0	application	Grdf-Parameter...
	4	0	0	0	0x2011	0	-	RO	r001	exception state	0: no exception	0: no exception	
	5	0	0	0	0x2012	0	-	RO	r002	warning bit	0: no warning	0: no warning	
	6	0	0	0	0x2013	0	-	RO	r003	warning state	0: no exception	0: no exception	
	7	0	0	0	0x2014	0	-	RO	r004	supply unit state	4: run	4: run	
	8	0	0	0	0x2015	0	-	RO	r005	rot. max. speed	0.0000 1/min	0.0000 1/min	
	9	0	0	0	0x2016	0	-	RO	r006	stomp out speed	0.0000 1/min	0.0000 1/min	
	10	0	0	0	0x2017	0	-	RO	r007	rot. frequency	0.0000 Hz	0.0000 Hz	
	11	0	0	0	0x2018	0	-	RO	r008	rot. value	0.0000 1/min	0.0000 1/min	
	12	0	0	0	0x2019	0	-	RO	r009	rot. encoder speed	0.0000 1/min	0.0000 1/min	
	13	0	0	0	0x201A	0	-	RO	r010	rot. apparent current	0.00 A	0.00 A	
	14	0	0	0	0x201B	0	-	RO	r011	rot. active current	0.00 A	0.00 A	
	15	0	0	0	0x201C	0	-	RO	r012	rot. reactive current	0.00 A	0.00 A	
	16	0	0	0	0x201D	0	-	RO	r013	peak apparent current	0.00 A	0.00 A	
	17	0	0	0	0x201E	0	-	RO	r014	rot. DC voltage	230.4 V	230.4 V	
	18	0	0	0	0x201F	0	-	RO	r015	rot. DC voltage	323.4 V	323.4 V	
	19	0	0	0	0x2020	0	-	RO	r016	rot. output voltage	0.0 V	0.0 V	
	20	0	0	0	0x2021	0	-	RO	r017	modulation grade	0.0 %	0.0 %	
	21	0	0	0	0x2022	0	-	RO	r018	slip. rot. state	0: no input	0: no input	
	22	0	0	0	0x2023	0	-	RO	r019	internal output state	0: no output	0: no output	
	23	0	0	0	0x2024	0	-	RO	r020	slip. output state	0: no output	0: no output	
	24	0	0	0	0x2025	0	-	RO	r021	slip. output flags	0: no flags	0: no flags	
	25	0	0	0	0x2026	0	-	RO	r022	reference torque	0.0 %	0.0 %	
	26	0	0	0	0x2027	0	-	RO	r023	rot. torque	0.0 %	0.0 %	
	27	0	0	0	0x2028	0	-	RO	r024	rotor temperature	20.0 °C	20.0 °C	
	28	0	0	0	0x2029	0	-	RO	r025	internal temperature	40.0 °C	40.0 °C	
	29	0	0	0	0x202A	0	-	RO	r026	rot. 2 counter	0.0 %	0.0 %	
	30	0	0	0	0x202B	0	-	RO	r027	rotor temperature	PTC open	PTC open	
	31	0	0	0	0x202C	0	-	RO	r028	rot. counter	0.0 %	0.0 %	
	32	0	0	0	0x202D	0	-	RO	r029	SAC3 comm state	30:0, enc. stop	30:0, enc. stop	
	33	0	0	0	0x202E	0	-	RO	r030	rotor ID state	4000: PR20 - 970:1 L...	4000: PR20 - 970:1 L...	
	34	0	0	0	0x202F	0	-	RO	r031	rotor proc. counter	0.0 %	0.0 %	
	35	0	0	0	0x2030	0	-	RO	r032	rotor actual value	0	0	



# COMBIVIS 6 - THE TOOL FOR ALL TASKS

## COMBIVIS 6

- Free and easy-to-use software for startup, administration and analysis
- Integrated start-up assistants (Wizards) for quick and easy configuration
- Direct access to device documentation
- 16 channel oscilloscope for extensive analysis
- Online parameter list comparison
- Parameterisation of key safety indicators and functions

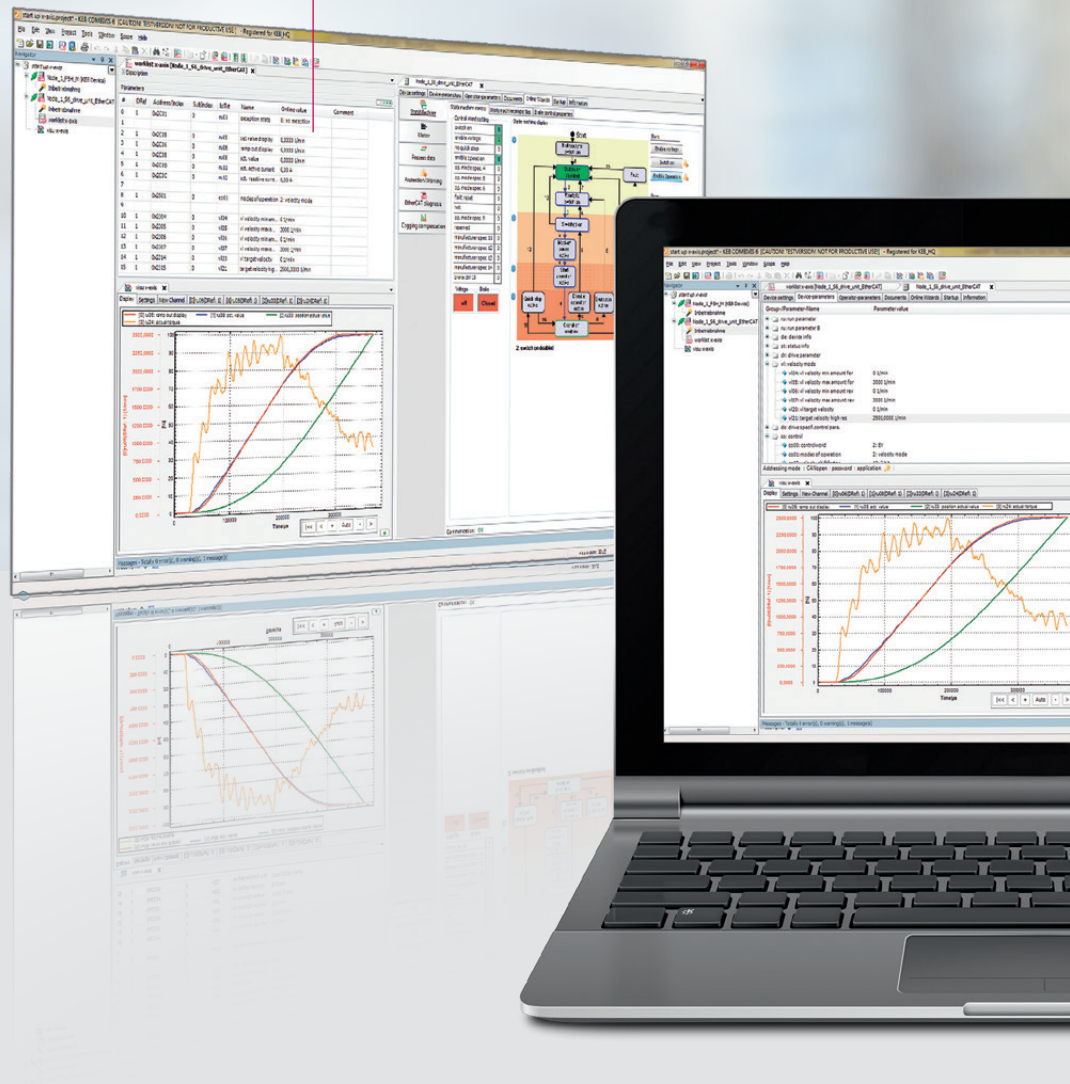

## COMBIVIS studio 6

The intelligent automation suite from KEB combines an assistant-guided component selection, fieldbus configuration, drive parameterisation, IEC 61131-3 project generation and motion control. Throughout the planning and layout phase, implementation of control sequences and multi-axis movement profiles, to start-up and fine tuning, the user is supported by a tool developed by experienced application engineers.

With a foundation built on libraries, devices and template databases, rapid and simple solutions can be generated for a wide range of applications.

**COMMISSIONING ASSISTANT**

- Complete user guidance through the commissioning process
- KEB Motor database, free for extensions
- Anti cogging
- Fieldbus diagnostic and optimisation

**SYSTEM CONFIGURATION AS A NEW COMPONENT OF COMBIVIS**

- Access to complete KEB product database
- Intuitive gear component selection and system configuration using drag and drop
- Selection assistant with display of compatible components
- Display of all interfaces and connection components
- Material number generator
- Extensive export function for COMBIVIS, Excel, etc.

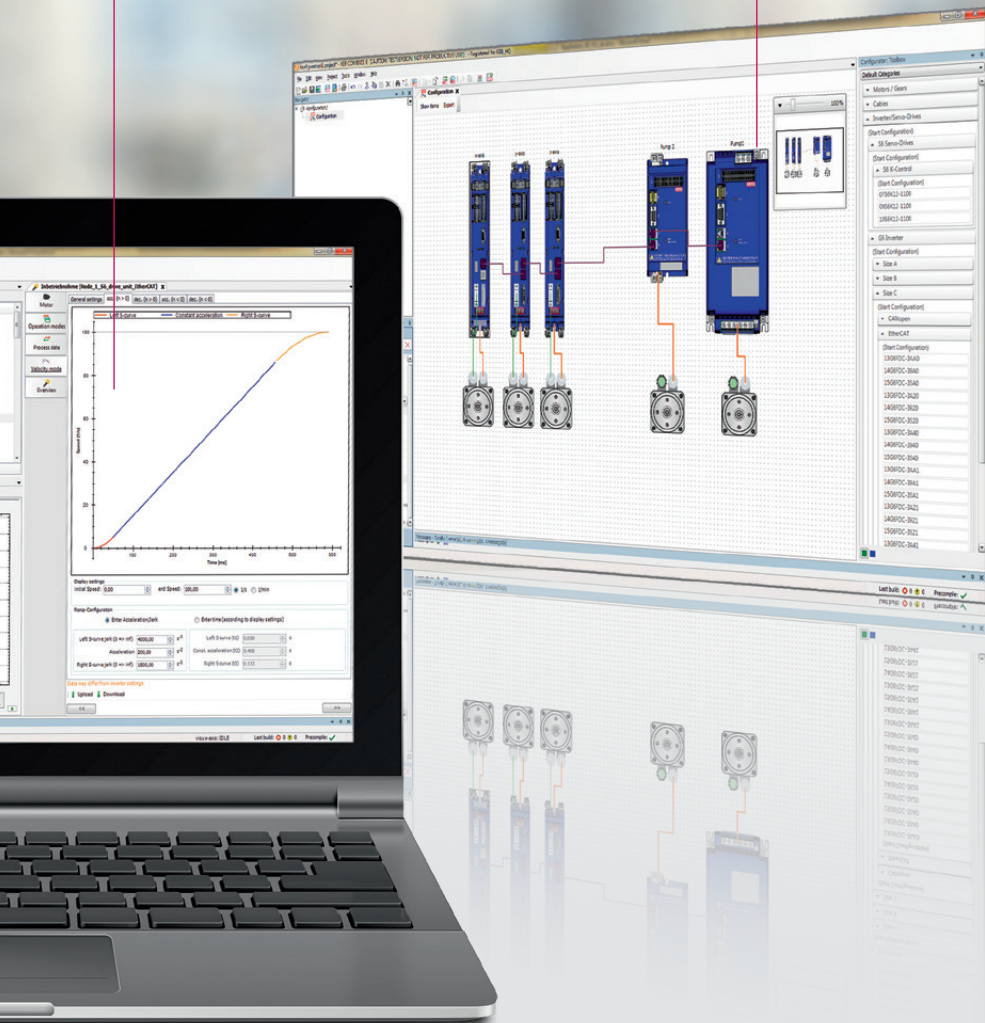

**HIGHLIGHTS**

- IEC 61131-3 Applications development
- Device and library database
- Product configuration
- Start-up and diagnosis assistant
- COMBIVIS studio HMI integration
- Document database

# KEB SERVICE

## PERFORMANCE AND COMPETENCE

### AFTER-SALES CUSTOMER SUPPORT

- Start-up support
- EMC service
- Mains analysis
- Insulation, heat or vibration measurements
- Conversion of old product series

### MAINTENANCE AND REPAIRS

- Rush or standard service

### COMPONENT AND SPACE PART SUPPLY

- Used and new parts for the exchange

### PREVENTIVE MAINTENANCE

- Forming and cleaning
- Inspection
- Functional analysis

### CUSTOMER SPECIFIC SERVICE

- Individual service support
- System optimisation

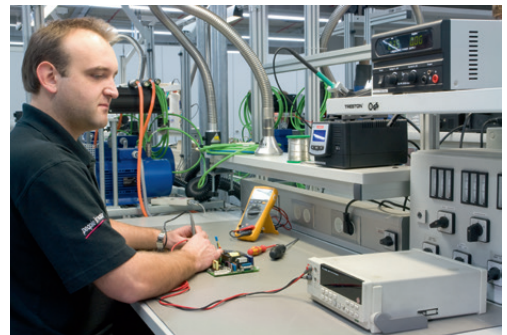

## KEB WORLDWIDE

**Austria** | KEB Automation GmbH

Ritzstraße 8 4614 Marchtrenk Austria  
 Tel: +43 7243 53586-0 Fax: +43 7243 53586-21  
 E-Mail: info@keb.at Internet: www.keb.at

**Benelux** | KEB Automation KG

Dreef 4 – box 4 1703 Dilbeek Belgium  
 Tel: +32 2 447 8580  
 E-Mail: info.benelux@keb.de Internet: www.keb.de

**Czech Republic** | KEB Automation GmbH

Videnska 188/119d 61900 Brno Czech Republic  
 Tel: +420 544 212 008  
 E-Mail: info@keb.cz Internet: www.keb.cz

**France** | Société Française KEB SASU

Z.I. de la Croix St. Nicolas 14, rue Gustave Eiffel  
 94510 La Queue en Brie France  
 Tel: +33 149620101 Fax: +33 145767495  
 E-Mail: info@keb.fr Internet: www.keb.fr

**Germany** | Geared Motors

KEB Antriebstechnik GmbH  
 Wildbacher Straße 5 08289 Schneeberg Germany  
 Telefon +49 3772 67-0 Fax +49 3772 67-281  
 E-Mail: info@keb-drive.de Internet: www.keb-drive.de

**Italy** | KEB Italia S.r.l. Unipersonale

Via Newton, 2 20019 Settimo Milanese (Milano) Italy  
 Tel: +39 02 3353531 Fax: +39 02 33500790  
 E-Mail: info@keb.it Internet: www.keb.it

**Japan** | KEB Japan Ltd.

15 - 16, 2 - Chome, Takanawa Minato-ku  
 Tokyo 108 - 0074 Japan  
 Tel: +81 33 445-8515 Fax: +81 33 445-8215  
 E-Mail: info@keb.jp Internet: www.keb.jp

**P. R. China** | KEB Power Transmission Technology (Shanghai) Co. Ltd.

No. 435 QianPu Road Chedun Town Songjiang District  
 201611 Shanghai P. R. China  
 Tel: +86 21 37746688 Fax: +86 21 37746600  
 E-Mail: info@keb.cn Internet: www.keb.cn

**Poland** | KEB Automation KG

Tel: +48 60407727  
 E-Mail: roman.trinczek@keb.de Internet: www.keb.de

**Republic of Korea** | KEB Automation KG

Deoksan-Besttel 1132 ho Sangnam-ro 37  
 Seongsan-gu Changwon-si Gyeongsangnam-do Republic of Korea  
 Tel: +82 55 601 5505 Fax: +82 55 601 5506  
 E-Mail: jaeok.kim@keb.de Internet: www.keb.de

**Russian Federation** | KEB RUS Ltd.

Lesnaya str, house 30 Dzerzhinsky MO  
 140091 Moscow region Russian Federation  
 Tel: +7 495 6320217 Fax: +7 495 6320217  
 E-Mail: info@keb.ru Internet: www.keb.ru

**Spain** | KEB Automation KG

c / Mitjer, Nave 8 - Pol. Ind. LA MASIA  
 08798 Sant Cugat Sesgarrigues (Barcelona) Spain  
 Tel: +34 93 8970268 Fax: +34 93 8992035  
 E-Mail: vb.espana@keb.de Internet: www.keb.de

**Switzerland** | KEB Automation AG

Witzbergstraße 24 8330 Pfaeffikon/ZH Switzerland  
 Tel: +41 43 2886060 Fax: +41 43 2886088  
 E-Mail: info@keb.ch Internet: www.keb.ch

**United Kingdom** | KEB (UK) Ltd.

5 Morris Close Park Farm Industrial Estate  
 Wellingborough, Northants, NN8 6 XF United Kingdom  
 Tel: +44 1933 402220 Fax: +44 1933 400724  
 E-Mail: info@keb.co.uk Internet: www.keb.co.uk

**United States** | KEB America, Inc.

5100 Valley Industrial Blvd. South  
 Shakopee, MN 55379 United States  
 Tel: +1 952 2241400 Fax: +1 952 2241499  
 E-Mail: info@kebameric.com Internet: www.kebameric.com



## KEB PARTNERS WORLDWIDE

... [www.keb.de/contact/contact-worldwide](http://www.keb.de/contact/contact-worldwide)



**Automation with Drive**

**[www.keb.de](http://www.keb.de)**

KEB Automation KG Südstrasse 38 32683 Bartrup Germany Tel. +49 5263 401-0 E-Mail: [info@keb.de](mailto:info@keb.de)

© KEB 0000000-5156 08.2020 Subject to technical alterations!